



Simple. Rugged. Reliable.

- Triple thread screw on/off cover - No more bolts!
- DPDT relay output
- Switch selectable high/low fail-safe
- Removable terminals for easy wiring
- Field adjustable sensitivity
- Dual conduit entrance for improved wiring access
- Hazardous location approval standard
- Built-in motor slip-clutch protects drive
- De-energized motor with sealed gear assembly
- Wetted parts are all stainless steel
- Four bearing design for greater shaft stability
- Powder coat finish
- Available in multiple voltages
- The best value on the market

BMRX Rotary Level Indicator

***BIN* MASTER®**

Model BMRX

Rotary Bin Level Indicator

New innovative design

We've refined our technology and designed new innovations into the BMRX to create a significantly advanced rotary level indicator. The BMRX is designed to provide security from system power failure, easy access to all components, and reliability through advanced circuitry. We've made the best rotary level indicator even better, providing the most cost-effective and easiest-to-implement solution for level control.

Only rotary with de-energizing motor, built-in slip clutch, and four bearing drive shaft

A rotary level indicator is only as reliable as its motor. BinMaster builds the BMRX with a specially designed synchronous motor that features "de-energized" operation. That is, the motor shuts down when material is present rather than entering a "stalled" condition. This reduces wear and operating temperature which extends motor life. Plus the motor has a built-in bidirectional slip-clutch that protects the gear assembly from damage due to over-rotation.

Unlike other rotary level indicators, the BMRX comes with a four-bearing drive shaft assembly. This unique design reduces motor drag during paddle rotation.

Applications

The BMRX is designed for controlling dry bulk material storage and flow in bins, hoppers, tanks, chutes and conveyors. Typical applications include feed, cement, grain, plastic, aggregates, and wood products. The BMRX can be used in materials with a bulk density as low as 2 lb/ft³ (30 kg/m³). By managing material storage and flow with the BMRX, you prevent bin overflows, empty conditions, clogged chutes, and jammed conveyors. This eliminates costly spills, material waste, and unnecessary down time.

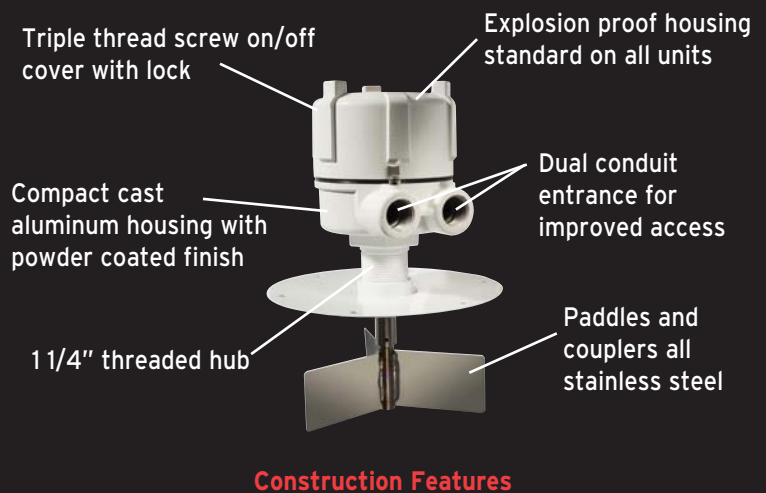
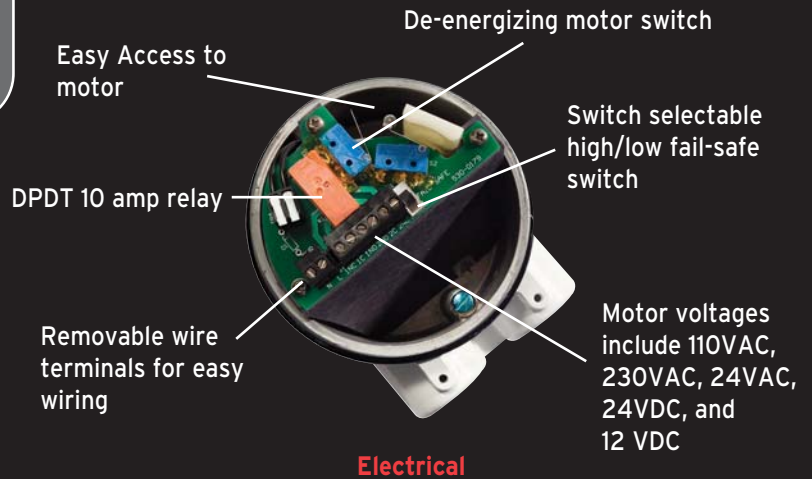

Principle of operation

The BMRX has few moving parts and features simple and dependable operation. A slow speed synchronous motor rotates a paddle which senses the presence of material at the level where the BMRX is placed.

As a high level control the paddle rotates continuously when the material is not present. When material reaches the paddle, the resistance causes the motor to "de-energize". This promptly causes a relay to change status and automatically shut-off any process system wired to the relay. As a low level control the paddle is stopped and the motor is "de-energized" when material is present. When material drops below the paddle the motor "energizes" and the paddle starts rotating. This causes the relay to change status and automatically start-up any process system wired to the relay.

Side Mount Installation

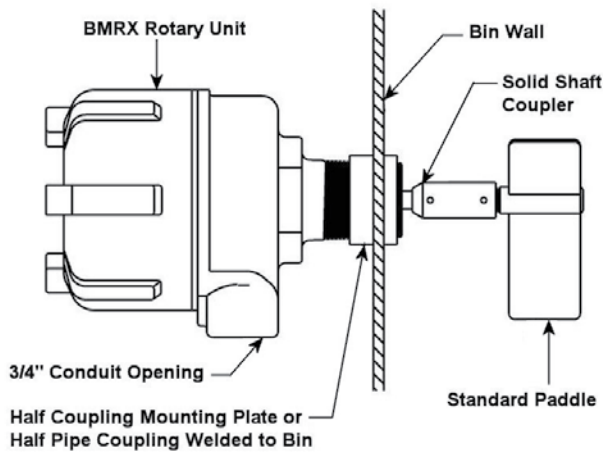

Side-of-bin mounting is recommended using a BinMaster half coupling mounting plate or 1/2 of a standard pipe coupling installed flush with the inside of the bin wall. A short solid shaft coupler is connected to the BMRX unit. The paddle should be placed out of the direct flow of the material. When this cannot be avoided, a protective shield over the paddle is recommended.

Mounting Plates

Mounting plates allow the BMRX rotary units to be mounted from the outside of a vessel on a curved or flat surface. A half coupling mounting plate is used in side mount installations. A full coupling mounting plate is for use in top mount installations where a shaft extension and shaft guards are required. Both mounting plates are available in powder coated carbon steel and stainless steel for use in corrosive environments.

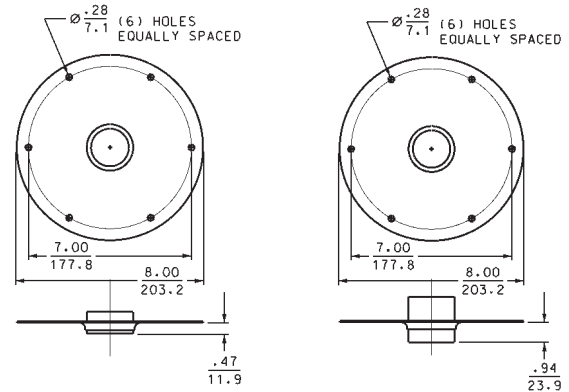

Half Coupling Mounting Plate

Full Coupling Mounting Plate

Top Mount Installation

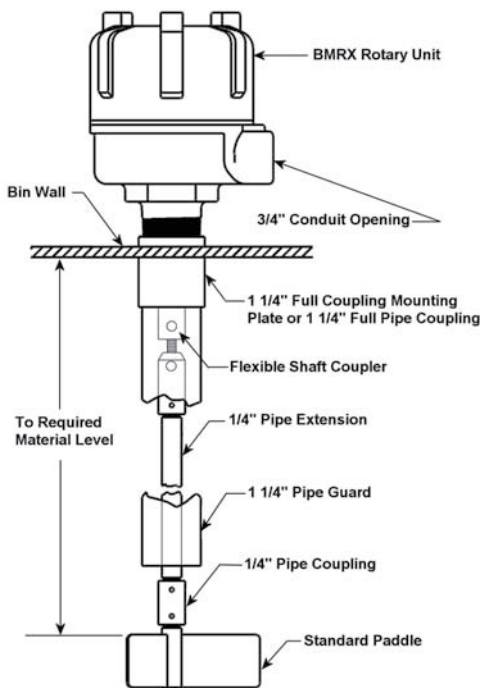

Top-of-bin mounting is recommended using a BinMaster full coupling mounting plate or a standard 1 1/4" pipe coupling. The length of the extension shaft (1/4" pipe) is extended to suit the application. A flexible coupler connects the shaft to the BMRX unit. Protective shaft guards are necessary on shaft extensions 24" (.6 m) or longer. The shaft guard should be adequately braced on longer shaft extensions.

Solid Shaft Coupler

Short solid shaft coupler should be used in side mount installations. It provides stability and protects the internal workings of the unit.

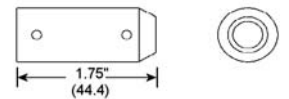

Flexible Shaft Coupler

The flexible coupler should be used in top mount installations to absorb side loads and protect the internal workings of the unit.

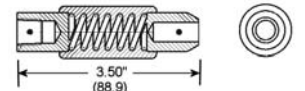

Pipe Extension

Top mount installation may require that the paddle extends into the vessel. Galvanized or stainless steel 1/4" diameter shaft extensions are available in a variety of lengths up to 144" (3.3 m).

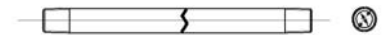

Pipe Guard

A pipe guard is recommended in top mount installations when the pipe extensions exceed 24" (.6 m). Pipe guards limit the movement of the pipe extension caused by side loading that can damage the rotary unit. The pipe guard should be the same length as the pipe extension and is available in galvanized or stainless steel.



Paddle Assemblies

<p>GRP-1 Stainless steel for light materials up to 30 lb/ft³. 3 vane paddle, 7" diameter.</p>	
<p>GRP-2 Stainless steel for medium materials 30 to 70 lb/ft³. 3 vane paddle, 5" diameter.</p>	
<p>GRP-3 Insertable stainless steel for heavy materials over 50 lb/ft³. Single vane, 5" diameter.</p>	
<p>GRP-22 Stainless steel for material over 40 lb/ft³. 3 vane paddle, 5" diameter.</p>	
<p>GRP-26 Direct connect (eliminates the need for GRSS-1 coupler). Version of GRP-1</p>	
<p>GRP-23 Insertable stainless steel paddle for medium materials 30 to 70 lb/ft³. Single bayonet vane paddle, 5" diameter.</p>	
<p>GRP-27 Direct connect (eliminates the need for GRSS-1 coupler). Version of GRP-23 paddle.</p>	
<p>GRP-28 Stainless steel for extremely light materials down to 2 lb/ft³. 3 vane paddle, 7" diameter.</p>	
<p>GRP-30 Direct connect (eliminates the need for GRSS-1 coupler). Version of GRP-2.</p>	
<p>GRP-11 Economical polyethylene paddle for light materials up to 30 lb/ft³. 3 vane paddle, 7" diameter.</p>	
<p>GRP-12 Economical polyethylene paddle for medium materials 30 to 70 lb/ft³. 3 vane paddle, 5" diameter.</p>	
<p>GRP-24 12" Belt paddle for use in heavy material with large particulate size.</p>	

Specifications

Power Requirements:	24/115/230 VAC 50/60 Hz; 24/ 12 VDC, 60/35 mA
Output Contacts:	DPDT 10 Amp 250 VAC
Operating Temperature:	-40°F to +185°F, (-40°C to +85°C)
Process Temperature:	to 400°F (to 204°C)
Pressure:	1/2 micron, 30 PSI
Approvals & Certifications:	Listed for Class I, Groups C & D and Class II, Groups E, F & G Hazardous Locations. Enclosure Type NEMA 4X, 5, 7, 9 & 12
Fail-Safe Mode:	Switch selectable between high & low
Enclosure:	Die cast aluminum, USDA approved powder coat finish
Mounting:	1-1/4" NPT
Conduit Connections:	3/4" NPT
Shaft and Components:	Stainless Steel
Paddles:	Stainless Steel

Mechanical

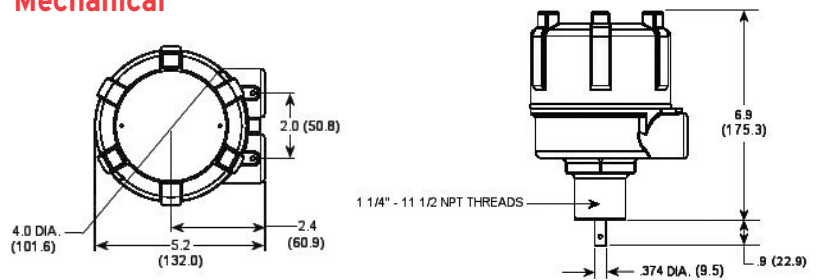

Electrical

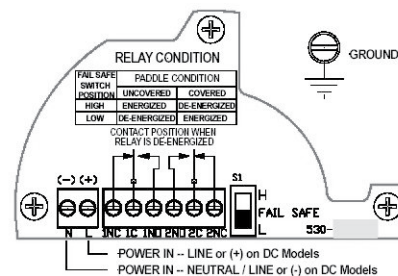

BINMASTER®

Shipping Address: 7201 N. 98th St., Lincoln, NE 68507
Mailing Address: P.O. Box 29709, Lincoln, NE 68529
Phone: 800-278-4241 or 402-434-9102 / Fax: 402-434-9133
www.binmaster.com / info@binmaster.com