



Fool-Proof. Rugged. Reliable.

- Supervise normal and fault conditions
- Microprocessor-based fail-safe circuitry
- De-energizing motor operation increases motor and gear life
- Built in motor slip-clutch protects drive
- Triple thread screw off/on cover—three simple turns and it's off/on
- Local LED indicates sensor status
- Switch selectable high/low fail-safe
- DPDT relay output
- Dual conduit entrance for improved wiring access
- Hazardous location approvals standard
- Available in multiple voltages

Maxima+ Rotary Level Indicator

***BIN* MASTER®**

Model Maxima+

Genuine Fail-Safe Rotary Bin Level Indicator

The rotary style level indicator is one of the most accepted and reliable point level switches used in powders and dry bulk solids. The rotary indicator can be made to work in about any dry bulk material with a variety of paddle and coupler options.

New, innovative fail-safe design

The Maxima+ is the state-of-the-art microprocessor-based fail-safe and fool-proof rotary level indicator. The distinguishing feature of the Maxima+ is its ability to continuously self diagnose, and in the event of a failure, give an immediate warning and instantaneous corrective response. This means the Maxima+ is the rotary of choice whenever it's crucial to confirm the continuous operation of the unit.

Motor and visual monitoring

A supervisory circuit monitors the motor shaft rotation with a slotted disk and digital optical encoder. In the absence of material, a drive motor freely rotates a paddle connected to the motor shaft. When material reaches the paddle, the resistance causes the motor to rotate and open a switch. This promptly causes the motor to "de-energize" and a DPDT process relay to change status. If the shaft stops turning because of a motor or electrical failure, the motor will not rotate and open the switch. The supervisory circuit observes no shaft rotation and looks to see if the switch is open. If the switch remains closed, the supervisory circuit detects a failure, causing the process relays to switch to a safe condition. A separate supervisory fault relay is activated by the supervisory circuit, indicating that there is some kind of unit failure rather than a normal alarm condition (high or low level alarm).

The supervisory circuit also sends a signal to an external LED, which indicates the sensor's status, giving a quick visual monitoring of paddle rotation, covered condition or fault condition. A pulse status relay is also provided for remote status monitoring.

Process control capability

Today, users demand more from their level controls than just material detection—they also want genuine fail-safe response. The Maxima+ was designed so that it can be integrated into process control systems. Its super smart circuitry lets the user monitor material levels and automatically control the process system if there is an unexpected unit failure or power loss. This means the Maxima+ gives you maximum protection and cost savings through added flexibility when designing a process control system.

Applications

The Maxima+ is designed for controlling dry bulk material storage and flow in bins, hoppers, tanks, chutes, and conveyors. Typical applications include feed, cement, grain, plastic, aggregates, and wood products. The Maxima+ can be used in materials with a bulk density as low as 2 lb/ft³ (30 kg/m³). By managing material storage and flow with the Maxima+, you prevent bin overflows, empty conditions, clogged chutes, and jammed conveyors. This eliminates costly spills, material waste, and unnecessary down time.



Principle of operation

The Maxima+ has few moving parts and features simple and dependable operation. A slow speed synchronous motor rotates a paddle which senses the presence of material at the level where the Maxima+ is placed.

As a high level control, the paddle rotates continually when the material is not present. When material reaches the paddle, the resistance causes the motor to "de-energize." This promptly causes a relay to change status and automatically shut-off any process system wired to the relay. As a low level control, the paddle is stopped and the motor is "de-energized" when material is present. When material

drops below the paddle, the motor energizes and the paddle starts rotating. This causes the relay to change status and automatically start-up any process system wired to the relay.

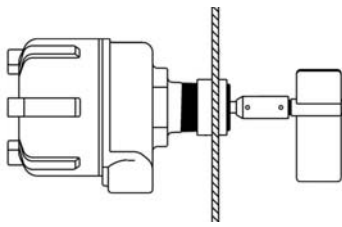

Side Mount Installation

Side-of-bin mounting is recommended using a BinMaster half-coupling mounting plate or 1/2 of a

standard pipe coupling installed flush with the inside of the bin wall. A short solid-shaft coupler is connected to the power pac. The paddle should be placed out of the direct flow of the material.

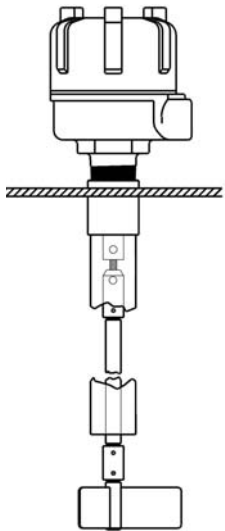

Top Mount Installation

Top-of-bin mounting is recommended using a BinMaster full coupling mounting plate or a standard 1 1/4" pipe coupling. The length of the extension shaft (1/4" pipe) is extended to suit the application. A flexible coupler connects the shaft to the power pac. Protective shaft guards are necessary on shaft extensions 24" or longer. The shaft guard should be adequately braced on longer shaft extensions.

OUTSIDE THE MAXIMA+

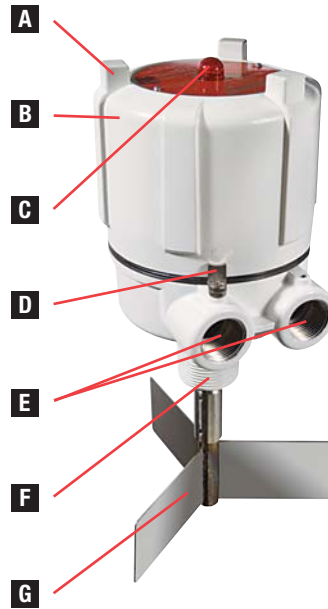

- A** Compact enclosure with screw on/off lid
- B** Epoxy powder coated finish
- C** LED light provides local visual indication
- D** Lid lock
- E** Dual conduit entries
- F** 1 1/4" threaded hub
- G** Stainless steel paddles & couplers

INSIDE THE MAXIMA+

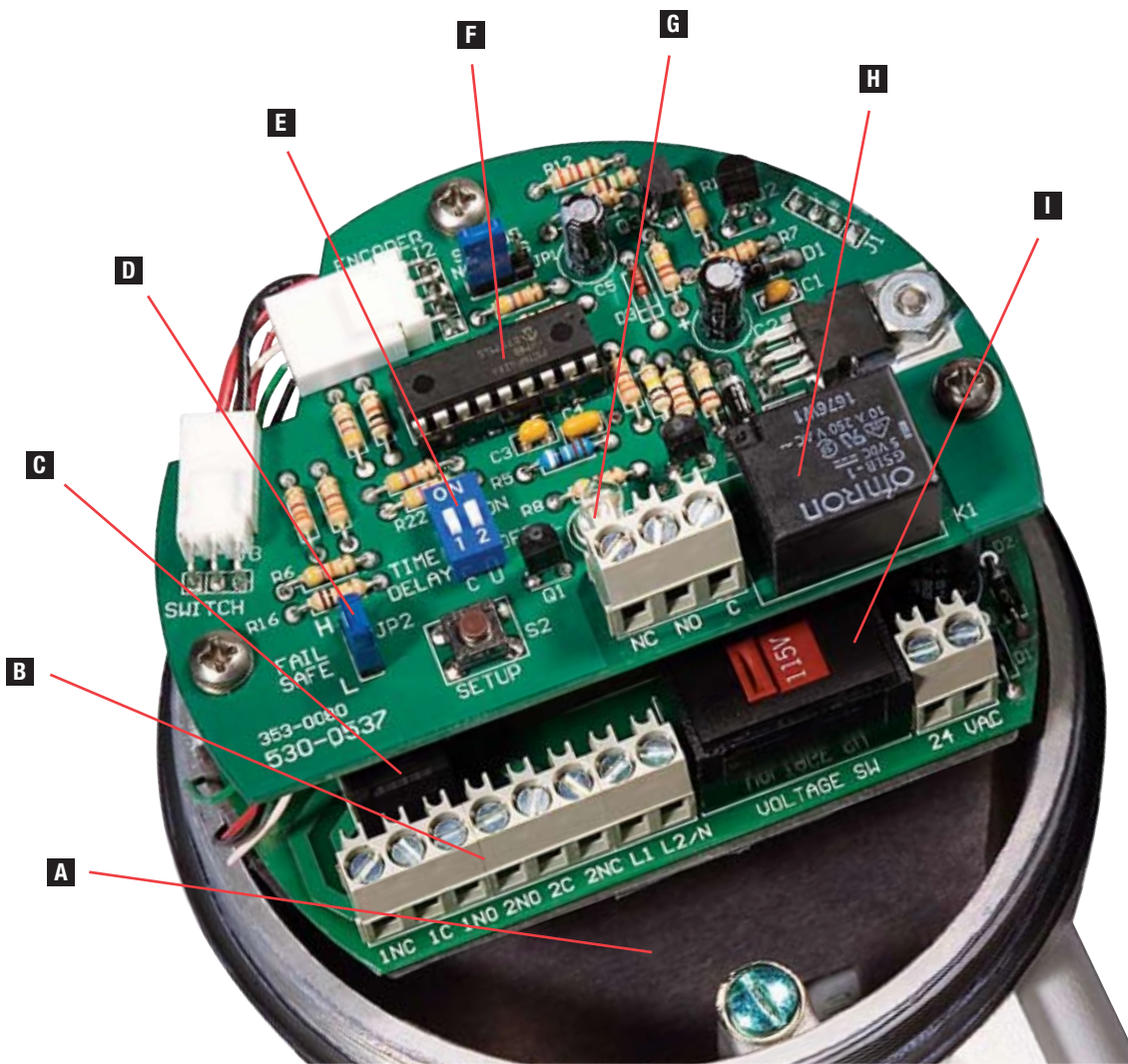

- A** Easy access to motor
- B** Wire terminals for easy wiring
- C** DPDT 10 Amp relay
- D** Switch selectable high/low fail-safe switch
- E** Time delay for both covered & uncovered conditions
- F** Microcontroller-based electronics ensures consistent and reliable operation
- G** LED light provides local visual indication
- H** Supervisory and pulse status relay
- I** Motor voltages include 115 VAC, 230 VAC, 24 VAC, 24 VDC, & 12 VDC

Paddle Assemblies

<p>GRP-1 Stainless steel for light materials up to 30 lb/ft³. 3 vane paddle, 7" diameter.</p>	
<p>GRP-2 Stainless steel for medium materials 30 to 70 lb/ft³. 3 vane paddle, 5" diameter.</p>	
<p>GRP-3 Insertable stainless steel for heavy materials over 60 lb/ft³. Single vane, 5" diameter.</p>	
<p>GRP-22 Stainless steel for material over 60 lb/ft³. 3 vane paddle, 5" diameter.</p>	
<p>GRP-26 Direct connect (eliminates the need for GRSS-1 coupler). Version of GRP-1</p>	
<p>GRP-23 Insertable stainless steel paddle for medium materials 30 to 70 lb/ft³. Single bayonet vane paddle, 5" diameter.</p>	
<p>GRP-27 Direct connect (eliminates the need for GRSS-1 coupler). Version of GRP-23 paddle.</p>	
<p>GRP-28 Direct connect (eliminates the need for GRSS-1 coupler). Version of GRP-23 paddle.</p>	
<p>GRP-30 Direct connect (eliminates the need for GRSS-1 coupler). Version of GRP-2.</p>	
<p>GRP-11 Economical polyethylene paddle for light materials up to 30 lb/ft³. 3 vane paddle, 7" diameter.</p>	
<p>GRP-12 Economical polyethylene paddle for medium materials 30 to 70 lb/ft³. 3 vane paddle, 5" diameter.</p>	
<p>GRP-24 12" Belt paddle for use in heavy material with large particulate size.</p>	

Specifications

Power Requirements:	24/115/230 VAC 50/60 Hz; 24/12 VDC, 60/35 mA
Output Contacts:	DPDT 10 Amp 250 VAC
Status Indicator Relay:	SPDT 10 Amp 250 VAC
Optional:	DC Solid State relay 1A 60 VDC
Optional:	AC Solid State Relay 1A 250 VAC
Operating Temperature:	-40°F to +158°F, (-40°C to +70°C)
Process Temperature:	to +400°F, (to +204°C)
Pressure:	1/2 micron, 30 PSI
Approvals:	Listed for Class II Groups E, F & G Hazardous Locations. Enclosure Type NEMA 4X, 5, 9 & 12
Fail-Safe Mode:	Switch selectable between high & low
Time Delay:	Selectable 5 seconds; Programmable to 25 seconds
Enclosure:	Die cast aluminum, USDA Approved powder coat finish
Mounting:	1-1/4" NPT
Conduit Connections:	3/4" NPT
Shaft and components:	Stainless Steel
Paddles:	Stainless Steel

Mechanical

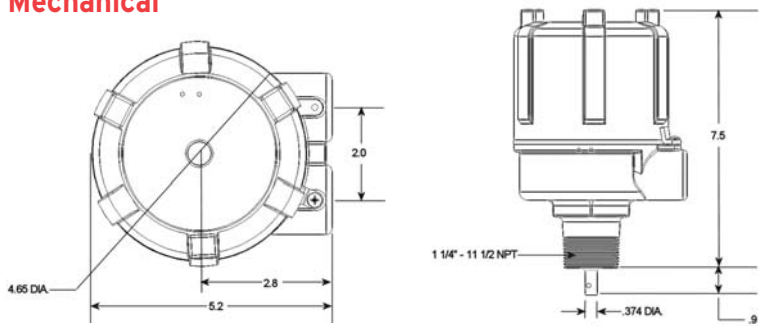

Electrical

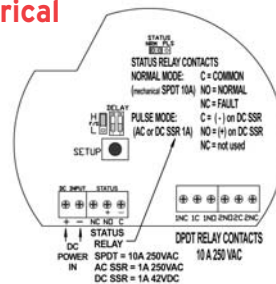

Fail-Safe "Low" Relay Contact Position

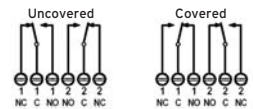

Fail-Safe "High" Relay Contact Position

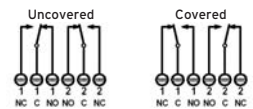

BINMASTER®

Shipping Address: 7201 N. 98th St., Lincoln, NE 68507
 Mailing Address: P.O. Box 29709, Lincoln, NE 68529
 Phone: 800-278-4241 or 402-434-9102 / Fax: 402-434-9133
www.binmaster.com / info@binmaster.com